

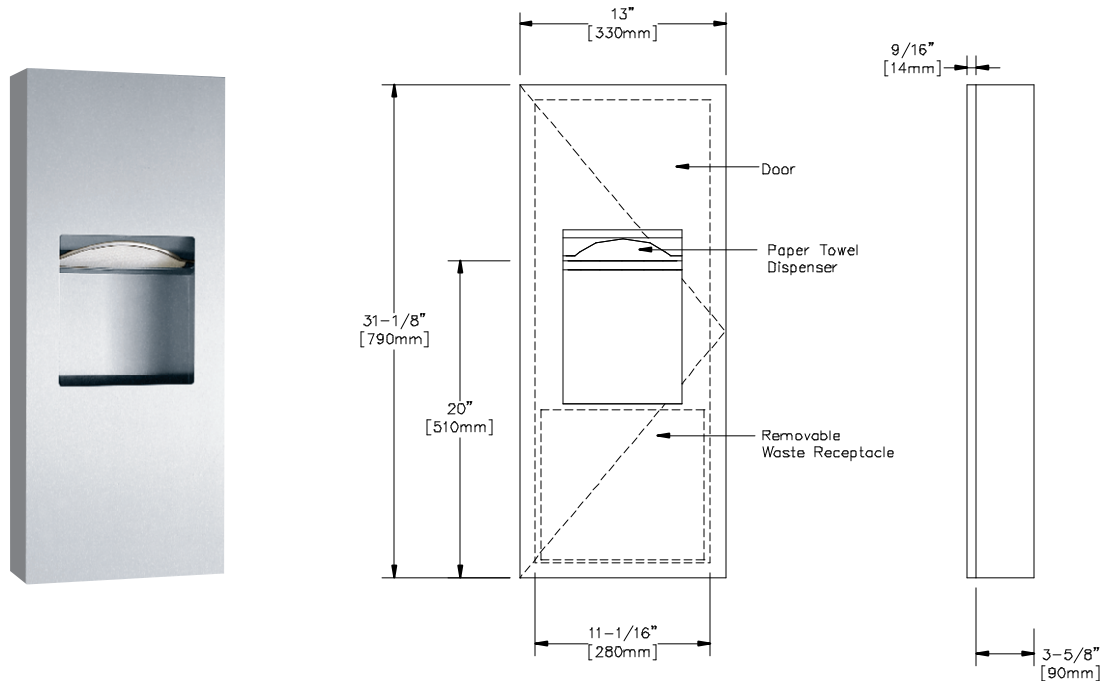

Technical Data

# SURFACE MOUNTED PAPER TOWEL DISPENSER AND WASTE RECEPTACLE

# B-369039



## MATERIALS:

**Cabinet** – 18-8 S, type-304, heavy-gauge stainless steel. All-welded construction.

**Flange** – 18-8 S, type-304, 22-gauge (0.8mm) stainless steel with satin finish. Drawn, one-piece, seamless construction.

**Door** – 18-8 S, type-304, 18-gauge (1.2mm) stainless steel. 9/16" (14mm) 90° return edges for maximum rigidity. Secured to cabinet with a concealed, full-length stainless steel piano-hinge. Equipped with a stainless steel cable door-swing limiter and friction catch.

**Paper Towel Dispenser** – 18-8 S, type-304, 22-gauge (0.8mm) stainless steel. Capacity: 300 C-fold or 400 multifold paper towels.

**Waste Container** – Removable, leakproof, rigid molded plastic. Capacity: 1.6 gal. (6.0 L).

## OPERATION:

Paper towel dispenser accommodates C-fold and multifold paper towels without adjustment or use of adapters. Waste receptacle is serviced by opening door and removing waste container. Door conceals flange from view. Cable door-swing limiter prevents damage to washroom accessories and walls.

## INSTALLATION:

Mount unit on wall with #8 x 1-1/4" (4.2mm x 32mm) sheet-metal screws (not furnished). For plaster or dry wall construction, provide concealed backing to comply with local building codes, then secure unit with sheet-metal screws. For other wall surfaces, provide fiber plugs or expansion shields for use with sheet-metal screws, or provide 1/8" (3mm) toggle bolts or expansion bolts. If unit projects above top of wainscot, provide aluminium channel or other filler to eliminate gap between unit and finish face of wall.

## SPECIFICATION:

Surface mounted paper towel dispenser and waste receptacle shall be type-304 stainless steel with all-welded construction. Exposed surfaces shall have satin finish. Flange shall be drawn, one-piece, seamless construction. Door shall be 18 gauge (1.2mm); have 9/16" (14mm) 90° return edges; be secured to cabinet with a concealed, full-length stainless steel piano-hinge; and equipped with a stainless steel cable door-swing limiter and friction catch. Door conceals flange from view. Paper towel dispenser shall be capable of dispensing 300 C-fold or 400 multifold paper towels without adjustment or use of adapters. Waste receptacle shall be furnished with a removable, leakproof, rigid molded plastic waste-container with a capacity of 1.6 gal. (6.0 L). Manufacturer's service and parts manual shall be provided to the building owner/manager upon completion of project.



RYNAT INDUSTRIES AUSTRALIA PTY LTD | [www.rynat.com](http://www.rynat.com) | Email: [sales@rynat.com](mailto:sales@rynat.com) |

| Aust Wide: 1300 558 518 | Tel: +61 8 6254 6555 | 20 Murray Rd South Welshpool WA |