



## Technical Data

# MIRROR WITH STAINLESS STEEL CHANNEL FRAME AND SHELF

**B-1666**  
**B-1668**  
**B-1669**

### SPECIAL-ORDER REFLECTIVE SURFACES

#### Specify Series Required:

- B-1666 Series Polished Stainless Steel Mirror — 24" x 48" (61 x 122cm) maximum; 12" x 12" (30 x 30cm) minimum.
- B-1668 Series Tempered Glass Mirror — 24" x 48" (61 x 122cm) maximum; 16" x 20" (41 x 51cm) minimum.
- B-1669 Series Laminated Glass Mirror — 24" x 48" (61 x 122cm) maximum; 12" x 12" (30 x 30cm) minimum.

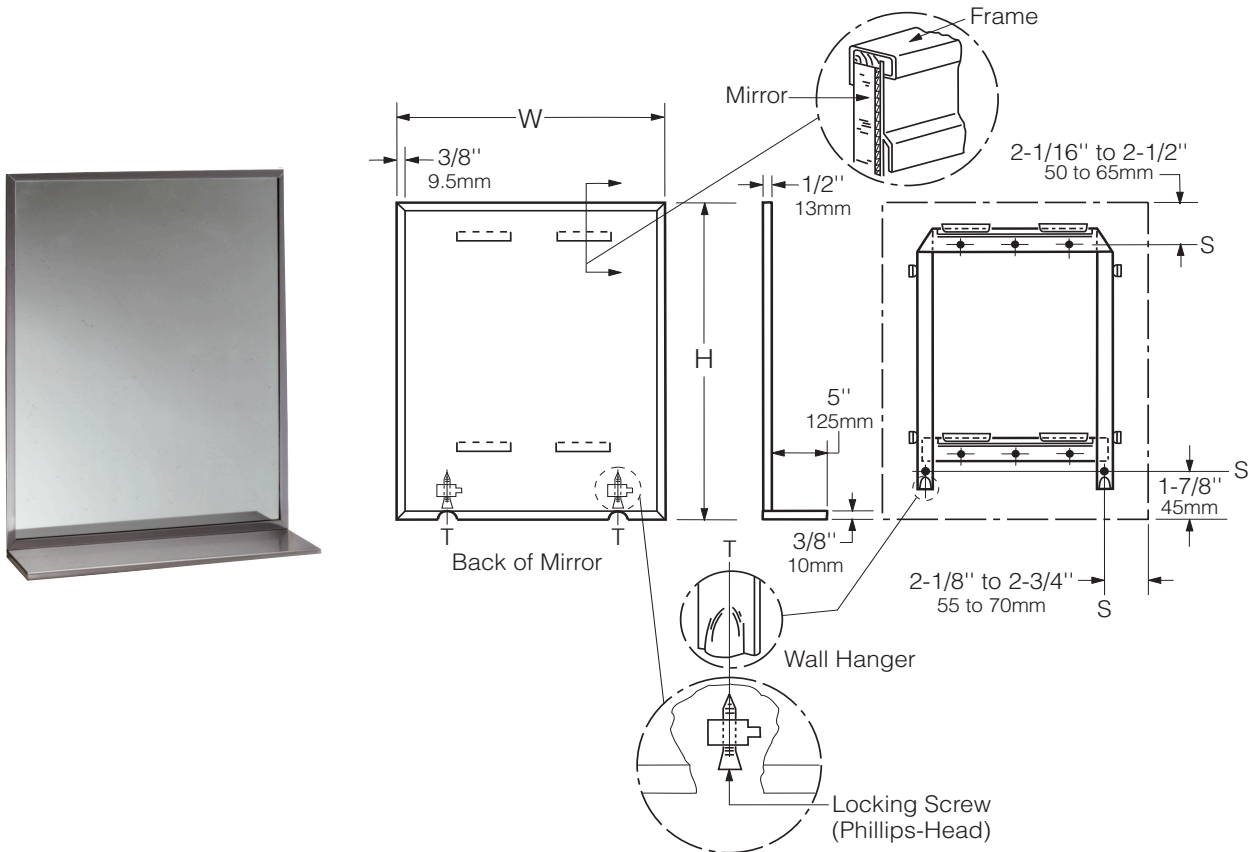

#### Designer's Notes:

1. Special-order only.
2. Maximum shelf length is 24" (61cm).
3. All Bobrick framed mirror/shelf models are manufactured to overall width and height dimensions including shelf.  
EXAMPLE: A 24" x 36" (61 x 91cm) mirror will be furnished 24" x 36" (61 x 91cm) outside-of-frame to outside-of-frame including shelf.
4. To specify sizes use Series Number followed by width then height in inches. EXAMPLE: B-1666 2024.
5. Bobrick framed mirror/shelf models are manufactured to a tolerance  $\pm 1/8"$  (3.2mm).
6. For sufficient space to lift mirror onto wall hanger(s), provide 2-7/8" (75mm) minimum clearance above center line of mounting screw holes.
7. Provide 1" (25mm) minimum clearance at bottom of mirror for engaging locking screws and 1" (25mm) clearance on each side.

continued . . .

## MATERIALS:

**Frame** — Type 430 stainless steel, 1/2" x 1/2" x 1/2" (13 x 13 x 13mm) channel with bright polished finish. One-piece frame with 90° mitered corners. Galvanized steel back with formed edges for additional strength has integral horizontal hanging brackets located near top. Concealed Phillips-head locking screws securely fasten mirror to wall hanger(s).

**Shelf** — 18-8 S, type 304, 22-gauge (0.8mm) stainless steel with satin finish. 3/8" (10mm) return edges on front and sides with front edge hemmed for additional safety. Shelf is welded to mirror frame and reinforced by concealed 16-gauge (1.6mm) stainless steel brackets. No exposed rivet-heads, screws, or fasteners of any type appear on frame or shelf.

**Mirror** — (B-1666 Series) Stretcher leveled stainless steel with reflective, highly polished strip finish. Tempered masonite backing.

(B-1668 Series) No. 1 quality, 1/4" (6mm) tempered select float glass: selected for silvering and electrolytically copper-plated by the galvanic process.

(B-1669 Series) 1/4" (6mm) thick. Two pieces of 1/8" (3mm) select float glass: selected for silvering, laminated with 0.003" (0.08mm) thick clear vinyl in the center, and electrolytically copper-plated by the galvanic process.

**Note:** These reflective surfaces resist breakage and provide a measure of safety from broken glass, but differ in color and reflective quality from standard glass mirrors.

Corners are protected by friction-absorbing filler strips. Backs of all glass mirrors are protected by full-size, shock-absorbing, water-resistant, nonabrasive, 3/16" (5mm) thick polyethylene padding.

**Concealed Wall Hanger(s)** — 20-gauge (0.9mm) x 15/16" (24mm) galvanized steel.

*Designer's Note:* Mirrors larger than 24" (61cm) high are supplied with wall hanger(s) that include lower support brace, welded construction, to form rigid rectangle.

## INSTALLATION:

Mount wall hanger(s) on wall with screws, (not furnished), at points indicated by an *S*. For plaster or dry wall construction, provide concealed backing to comply with local building codes, then secure wall hanger(s) with screws (not furnished). For other wall surfaces, provide fiber plugs or expansion shields for use with screws (not furnished), or provide 1/8" (3mm) toggle bolts or expansion bolts. Hang mirror on wall hanger(s). Lock mirror to wall hanger(s) by tightening Phillips-head locking screws that are concealed in bottom of frame at points indicated by a *T*.

## SPECIFICATION:

Mirror shall have a one-piece type 430 stainless steel channel frame, 1/2" x 1/2" x 1/2" (13 x 13 x 13mm), with 90° mitered corners; all exposed surfaces shall have bright polished finish. Shelf shall be type-304, 22-gauge (0.8mm) stainless steel with satin finish and shall have 3/8" (10mm) return edges on front and sides with front return edge hemmed. Shelf shall be welded to mirror frame and reinforced by concealed stainless steel brackets. No rivet-heads, screws, or fasteners of any type shall be exposed on frame or shelf. Mirror shall be \_\_\_\_\_ (insert one: polished stainless steel, tempered glass, or laminated glass). Corners shall be protected by friction-absorbing filler strips. Backs of all glass mirrors shall be protected by full-size, shock-absorbing, water-resistant, nonabrasive, 3/16" (5mm) thick polyethylene padding. Galvanized steel back shall have integral horizontal hanging brackets located near top for mounting on conceal wall hanger(s). Mirror shall be secured to wall hanger(s) with concealed Phillips-head locking screws located in bottom of frame.



RYNAT INDUSTRIES AUSTRALIA PTY LTD | [www.rynat.com](http://www.rynat.com) | Email: [sales@rynat.com](mailto:sales@rynat.com) |

| Aust Wide: 1300 558 518 | Tel: +61 8 6254 6555 | 20 Murray Rd South Welshpool WA |